



**MODVEST HOLDINGS** (Pty) Ltd  
AT YOUR SERVICE



**COMPANY PROFILE**

**2024**

# CONTENTS

<b>03</b>	Introduction
<b>04</b>	Our Vision, Mission
<b>05</b>	Our Values
<b>06</b>	Our Products & Services
<b>07</b>	Electrical Products / Services
<b>12</b>	Control & Instrumanatation
<b>14</b>	Vacuum Trucks
<b>15</b>	Yellow Plant Hire
<b>15</b>	Yellow Plant Repair & Service
<b>15</b>	Labour Hire
<b>15</b>	Refurbishment of Spares
<b>16</b>	Hydraulic Spares Supply
<b>16</b>	Yellow Plant Spare Supply
<b>17</b>	Health & Safety
<b>18</b>	Why Choose Us
<b>19</b>	Contacts

# ABOUT US

Founded in 2015, Modevest Holdings is a reputable private company specializing in the industrial supply sector. Our commitment to reliability and professionalism sets us apart as a trusted business partner. Catering to both government and private sectors, we offer a diverse range of services that include mechanical engineering, electrical engineering and supply, CNI services, and vacuum truck services.

At Modevest Holdings, we understand the importance of maintaining high standards. That's why we are registered with the Central Suppliers Database under MQA Number: MAAA0376475. Additionally, our company has obtained registration with the Company Intellectual Property of South Africa, reinforcing our dedication to compliance and best practices. We are proud to hold a Level 1 B-BBEE rating, showcasing our commitment to promoting economic transformation and empowerment.

Located in Mpumalanga, South Africa, our head office serves as the hub for our operations. Situated in a strategic location, we ensure seamless coordination and prompt delivery of services, enabling us to exceed customer expectations and build long-lasting partnerships.

With our solid foundation established in 2015, Modevest Holdings continues to be a reliable and respected player in the industrial supply sector. Our unwavering focus on quality, compliance, and customer satisfaction makes us the ideal choice for your industrial supply needs. Partner with us and experience the Modevest difference.



## COMPLIANCE



CIPC CERTIFICATION



B-BBEE CERTIFICATION



CSD CERTIFICATION





# **OUR VISION**

## **MISSION, CORE VALUES & BEE**

---

### **Mission Statement**

**We endeavor to expedite client demands according to specifications and on time.**

### **Our Vision**

Our vision is to establish a global reputation for excellence through providing turnkey built environment, electrical and mechanical engineering solutions, one client at a time.

### **B-BBEE**

Modvest Holdings is certified as Level 1 B-BBEE. We are thrilled by this acknowledgement of the significant transformational role we play in South Africa and believe that this rating will accelerate our contribution to our country's economic sustainability at a grass-roots level.

### **Core Values**

**Quality - Professional - Reliable - TeamWork - Efficient**



# OUR VALUES

At Modvest Holdings, we have always grasped the significance of core values as a fundamental cornerstone for our success. Our distinctive and shared company culture is built upon these core values.



## Quality Products/Services

We strive to consistently deliver exceptional products and services that meet the highest standards, ensuring customer delight and long-term loyalty.



## Client Satisfaction

Our primary focus is the satisfaction of our clients. We listen, understand their needs, and go the extra mile to deliver personalized solutions, building enduring partnerships based on trust and exceptional



## Efficient Service Delivery

We strive to consistently deliver exceptional products and services that meet the highest standards, ensuring customer delight and long-term loyalty.



## Professionalism

We conduct ourselves with the utmost professionalism in all aspects of our work. We adhere to ethical standards, demonstrate integrity, and maintain a high level of expertise, instilling confidence in our clients and stakeholders.



## Teamwork

Collaboration and mutual support are at the core of our success. We foster a culture of inclusivity and cooperation, empowering our diverse teams to achieve collective goals and celebrate shared

# PRODUCTS AND SERVICES

Modvest Holdings offers a diverse range of products and services tailored to meet the specific needs of the industrial and government sectors. With expertise in electrical engineering, control and instrumentation, and vacuum truck services, we provide comprehensive solutions to optimize operational efficiency and productivity. Our team of professionals leverages state-of-the-art technology and adheres to industry standards to deliver high-quality solutions. Whether it's designing and maintaining electrical systems, implementing process control and automation, or providing industrial cleaning and waste removal, Modvest Holdings is committed to ensuring a safe and clean working environment for our clients.

## Our Business Units

---



### **ELECTRICAL PRODUCTS AND SERVICES**

---



### **CONTROL AND INSTRUMENTATION**

---



### **YELLOW PLANT & VACUUM TRUCK**

---

# ELECTRICAL ENGINEERING

Expert Electrical Engineering Solutions: Empowering Industries with Innovative Power and Control Solutions



# INDUSTRIAL BULKHEAD B40 RETROFIT

We supply reliable, high-efficiency LED lighting designed for demanding industrial and commercial environments. Our range includes versatile floodlights, durable bulkheads, and advanced highbay units, each built to deliver strong illumination, low energy use, and long service life for applications such as warehouses, production areas, and outdoor sites.

## INDOOR LIGHTING

- ▶ COMMERCIAL INDUSTRIAL
- ▶ RETAIL FOOD & RESTAURANT
- ▶ HORTICULTURAL
- ▶ MEDICAL SCHOOLS

## OUTDOOR LIGHTING

- ▶ STREET LIGHTING
- ▶ STADIUM / SPORTS LIGHTING
- ▶ AREA & PERIMETER LIGHTING
- ▶ SIGNAGE
- ▶ PARKS
- ▶ PETROL STATIONS
- ▶ CUSTOMIZED SOLUTIONS

## TITAN LED BULKHEAD

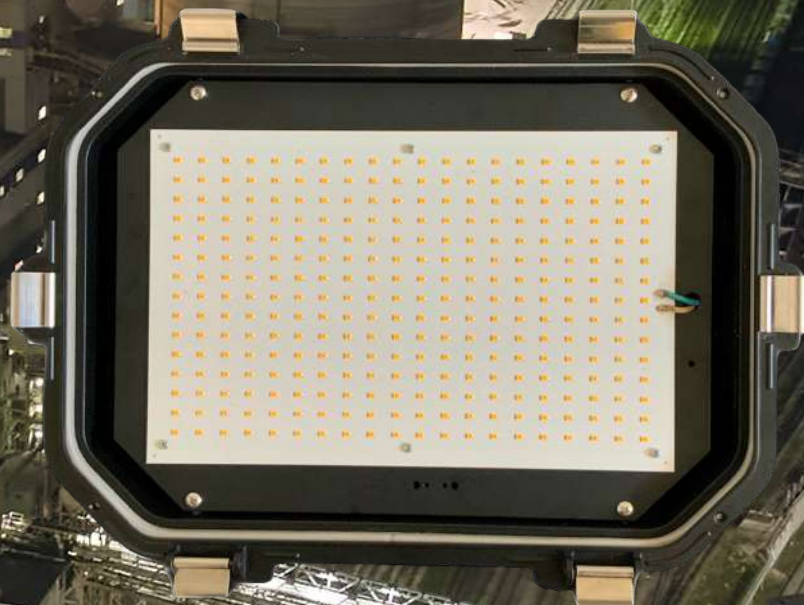

## KEY SPECIFICATIONS

- ▶ Model: BHT60
- ▶ Power: 60W
- ▶ Luminous Flux: 9600lm
- ▶ Efficacy: 160lm/w\*
- ▶ IP Rating: IP66
- ▶ Impact Rating: IK10
- ▶ Dimming: 1-10V



# TITAN LED FLOOD LIGHT

A high-performance, versatile floodlight designed for South African conditions. The Titan delivers exceptional efficiency and durability, operating interchangeably between highway, floodlight, and high-mast applications. It features a rugged IP65 and IK08 rating, built-in surge protection, and is engineered for easy installation and long-term, maintenance-free operation.

## FEATURES

140 -165LM/W\*

IP65 IK08

4KV built in Surge protection

Corrosion Resistant

L70B10 Lumen Maintenance

3 Step Macadam Elipse

50 000hrs

Energy Efficient

Low Maintenance

Made in South Africa



## SERIES



**200W LED FLOODLIGHT**



**75 -100W LED FLOODLIGHT**



**150W LED FLOODLIGHT**

# LED HIGHBAY LIGHT

An efficient and flexible high bay light designed for industrial and commercial spaces. Its key feature is the adjustable beam angle, allowing the light distribution to be tailored to the specific application. With a high-efficacy output and a robust design, it is perfect for warehouses, factories, and large retail areas.



## KEY SPECIFICATIONS



- ▶ Model: ELHB150
- ▶ Power: 150W
- ▶ Luminous Flux: 23,250 lm
- ▶ Efficacy: 155 lm/W
- ▶ Adjustable Beam Angles: 60°, 90°, 105°
- ▶ Ingress Protection: IP65
- ▶ Impact Protection: IK08
- ▶ Dimming: 1-10V
- ▶ Color Temperature: 5000K
- ▶ Warranty: 5 Years

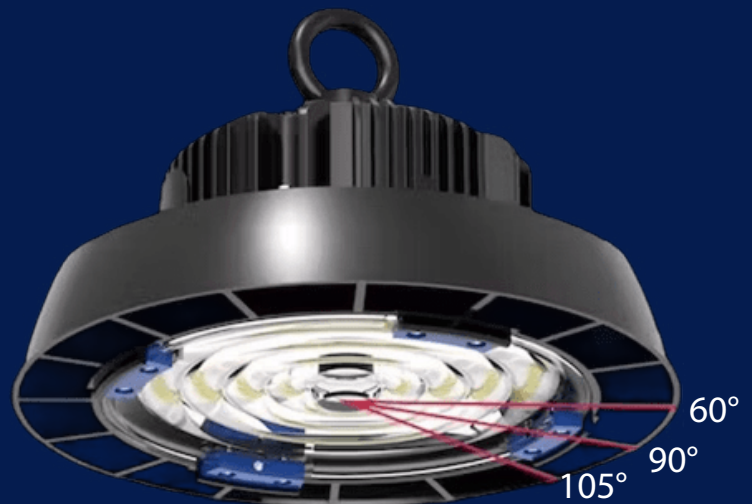

Adjustable Beam Angle LED Highbay

# ELECTRICAL ENGINEERING SERVICE

Our electrical engineering services are guided by a commitment to professionalism and excellence. Through strict adherence to industry standards, rigorous training, and a focus on continuous improvement, we consistently deliver

## Our Electrical Engineering Service includes the following:

### ■ Electrical Reticulation

Our expert team designs and executes reliable electrical distribution systems to ensure uninterrupted power supply and optimal performance

### ■ Electrical Maintenance & Supplies

Our proactive and reliable electrical maintenance services ensure smooth operations and minimal downtime for your systems.

### ■ Renewable Energy Systems

Harnessing clean energy sources, we provide innovative solutions for sustainable power generation, reducing environmental impact.

### ■ Electrical Consulting

- ▶ Power system optimization & audit
- ▶ Power system protection
- ▶ Onsite oil conditioning & onsite transformer repairs
- ▶ substation & MV Equipment –design to commissioning
- ▶ MV equipment maintenance and verification
- ▶ Protection & breaker maintenance
- ▶ Mine ready equipment



# CONTROL & INSTRUMENTATION

Empowering Industries with Advanced Control and Instrumentation  
Solutions for Optimal Performance



# CONTROL & INSTRUMENTATION

Control & instrumentation is a crucial aspect of industrial operations, and our services prioritize its seamless performance. We ensure accurate calibration, meticulous testing, and reliable maintenance, providing clients with the confidence they need for efficient and error-free control of their systems.



## **Our Control and Instrumentation Service includes the following:**

- ▶ Plant analysis and optimization
- ▶ Plant Commissioning
- ▶ Process and instrumentation diagrams (ISA)
- ▶ Trouble shooting existing systems
- ▶ Control valve sizing and selection
- ▶ Pneumatic controls for modulating applications
- ▶ Variable speed drive applications for pumps motors and fans
- ▶ Instrument calibrations and start up
- ▶ Cable racking and routing
- ▶ Panel design and wiring
- ▶ Signal Wiring
- ▶ Instrument selections and applications
- ▶ PLC Engineering software
- ▶ Fieldbus Insallations
- ▶ Feasibility studies

# VACUUM TRUCK

Our vacuum truck services are designed to handle a wide range of tasks, including liquid and sludge removal, spill cleanup, hydro-excavation, tank cleaning, and more. We utilize advanced technology and powerful vacuum systems to efficiently and effectively handle various materials, ensuring thorough cleaning and waste removal.

## Our Vacuum Truck Service includes the following:

### ■ Liquid and sludge removal

Our industrial vacuum trucks efficiently remove liquid waste, sludge, and other materials from tanks, pits, and confined spaces.

### ■ Spill cleanup

Our vacuum trucks are equipped to handle emergency spill cleanup, quickly and effectively removing hazardous substances and preventing environmental contamination.

### ■ Dry material collection

Our vacuum trucks have the capability to collect and transport dry materials such as powders, granules, and solids, facilitating efficient cleanup and disposal.

### ■ Tank Cleaning

We provide tank cleaning services using industrial vacuum trucks, ensuring thorough removal of residues, sediments, and debris, maintaining optimal tank performance.

### ■ Slurry and drain cleaning

Our trucks are equipped with powerful vacuum systems to clear sewer lines and drains, effectively removing blockages and restoring proper flow.

### ■ Bulk material transfer:

With their large storage capacity, our vacuum trucks enable efficient transfer of bulk materials, such as sand, gravel, and aggregates, for construction or industrial purposes.

### ■ Industrial spill response:

We provide rapid spill response services, deploying vacuum trucks to contain and remove hazardous materials, minimizing the environmental impact and ensuring compliance with regulations.



# YELLOW PLANT HIRE

At Modvest Holdings, we offer a comprehensive selection of Yellow Plant equipment for hire, tailored to meet diverse construction needs. Our inventory includes TLBs, excavators, wheel loaders, skidsteers, telehandlers, graders, water carts, rollers, dump trucks, dozers, bobcats, and trucks with various capacities.



## LIST OF YELLOW PLANT EQUIPMENTS FOR HIRE:

- ▶ Skidsteers
- ▶ Telehandlers
- ▶ Graders
- ▶ Water Carts
- ▶ Rollers
- ▶ Front Loaders
- ▶ Dump trucks
- ▶ Dozers
- ▶ Bobcats
- ▶ Trucks
- ▶ Excavators

## REPAIR AND MAINTENANCE

At Modvest Holdings, we specialize in comprehensive repair and maintenance services for all types of earth-moving equipment. Our skilled technicians are trained to handle everything from routine inspections and preventive maintenance to major repairs and component replacements. We use only high-quality parts and the latest diagnostic tools to ensure your machinery operates at peak efficiency. Whether it's hydraulic systems, engine overhauls, or electrical repairs, we are committed to minimizing downtime and extending the life of your equipment.

## STOCKPILE MANAGEMENT

Our stockpile management service ensures efficient storage, handling, and quality control of extracted materials, optimizing operations. This service is available on a contract basis only.

# LABOUR HIRE

At Modvest Holding, we have a team of skilled technicians on standby to meet your labor hire needs, whether for construction projects or manual labor. Our service offers both skilled and semi-skilled labor to ensure you have the right expertise for your specific requirements. We are dedicated to providing reliable qualified workers who can seamlessly integrate into your projects and contribute effectively.

## REFURBISHMENT OF SPARES

### ■ Gearboxes:

Refurbishment includes repairing internal components, reconditioning gears, and ensuring proper alignment and lubrication for smooth operation.

### ■ Hydraulic Cylinders:

Refurbishment involves resealing, honing, and replacing worn-out seals and rods to restore hydraulic performance and prevent leaks.

### ■ Rollers:

Repairing or replacing worn rollers to ensure proper support and reduce friction in the track system.

### ■ Frames and Chassis:

Includes repairing cracks, reinforcing welds, and addressing structural damage to ensure the frame's strength and stability

### ■ Buckets:

Includes replacing or welding new wear plates, sharpening edges, and repairing structural damage to enhance durability and functionality.

### ■ Track Chains:

Refurbishment includes replacing worn-out links and pins, and reconditioning track shoes to improve tracking and operational efficiency.

### ■ Hydraulic Pumps:

Refurbishment involves overhauling pumps, replacing worn components, and testing performance to ensure efficient hydraulic system operation.

### ■ Booms and Sticks:

Repairing structural damage, reinforcing welds, and replacing worn bushings to ensure structural integrity and operational efficiency.



# HYDRAULIC SPARES SUPPLY

We offer a wide range of high-quality hydraulic parts, including pumps, valves, cylinders, and hoses. Our products are designed to be durable and reliable, ensuring that your equipment operates smoothly. We focus on providing excellent customer service with expert support, competitive pricing, and a large selection of parts to meet your needs. Whether you work in industry, construction, or agriculture, we are here to help keep your machinery running efficiently.



## LIST OF HYDRAULIC SPARES WE SUPPLY

- ▶ Hydraulic Cylinders
- ▶ Safety relief Valves
- ▶ Hydraulic Control Valves
- ▶ Hydraulic Hoses
- ▶ Hydraulic Pumps
- ▶ Full Hydraulic gear Box
- ▶ Variable speed drive applications for pumps
- ▶ Gear Hydraulic Wheel Motor
- ▶ Hydraulic Steering Valve Kits
- ▶ Gouging off Liners
- ▶ Liner Repair on Dozer and Excavator

## PROCUREMENT OF YELLOW PLANT SPARES

Our procurement service specializes in sourcing high-quality spares for yellow plant equipment, ensuring optimal performance and longevity of your machinery. We partner with trusted manufacturers to provide genuine and reliable parts tailored to your specific needs. Our efficient supply chain management ensures timely delivery, minimizing downtime and maintaining your operations' momentum.

- ▶ Engine parts
- ▶ Filters
- ▶ Specialized fittings
- ▶ Tires

# SAFETY HEALTH & ENVIRONMENT

---

“The health and safety of everyone on our sites and projects is our number one priority.”

It is of paramount importance to our business to ensure that our facilities are safe and that we reduce the environmental impact of our products as well as processes. We do this by applying the appropriate workplace and environmental protection technologies and by closely monitoring our daily activities in orders to prevent accidents, injuries, pollution and any other causes to harm to personnel & the environment.

It is the priority of our business to prevent harm to our employees and the environment by complying with all health, safety and environmental rules and regulations.

We WILL continuously strive to improve safety and environmental performance in all our activities throughout the existence of the company. We will ensure that all new employees as well as partners along the way are also made to understand and adhere to these safety rules and procedures. We pride ourselves not only in the ability to innovate but also comply with all the health & safety standards expected within the engineering field.

---

# WHY CHOOSE MODVEST HOLDINGS

At Modvest Holdings, we stand out as a trusted and reliable engineering contractor services provider. With our team of skilled professionals, we offer a wide range of expertise in electrical engineering, control and instrumentation, and vacuum truck services.

We have the knowledge and experience to handle various project requirements effectively.

Our Quantity Surveying team excels in developing detailed and accurate cost estimates, ensuring transparency and control throughout the project. We prioritize delivering projects within the agreed-upon budget.

Our Procurement team has established connections with a network of local and international suppliers. This enables us to source high-quality materials and components while considering client preferences for localization, ultimately providing the best value for your project.

Modvest Holdings' Project and Construction Managers are dedicated to delivering projects seamlessly. They coordinate all necessary resources, including engineering, fabrication workshops, and construction, to ensure that projects are executed according to the highest standards of quality, while adhering to cost and schedule requirements.

Our team consists of Engineering Professionals and a skilled construction workforce, bringing their expertise and dedication to every project we undertake. We are committed to delivering exceptional results and exceeding client expectations.

# Thank You



**MODVEST HOLDINGS** (Pty)Ltd  
AT YOUR SERVICE

Head Office: 4B Langa Crescent Corridor Hills,  
EMalahleni 1035

Phone: (+27) 082 594 4097

Fax: (+27) 086 510 7918

Email: [modvestholdings@outlook.com](mailto:modvestholdings@outlook.com)

REG No: 2015/165678/07  
TAX No: 9018468257  
CSD No: MAAA0376475